



MAKE: SSANGYONG **TYPE:** Rexton (Series II)



MODEL: RX270 XDI (Rigid Axle) **YEAR:** 2006 on
RX270 SPR (Independent Suspension)

DETAIL: Station Wagon

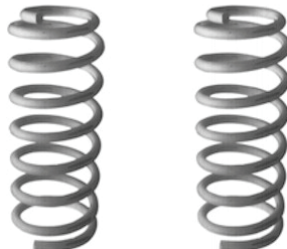
SSAN-53

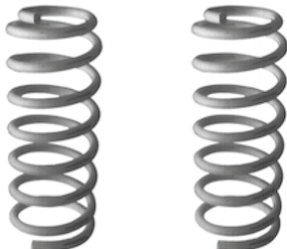

FRONT		TYPE	QTY	PART NUMBER
COIL SPRING Type 'C' 				
	Linear Rate Standard Height		1	C53-002 (Pair)
	Linear Rate Raised Height (35mm Lift)		1	C53-004 (Pair)
	Linear Rate Raised Height (40mm Lift) 50-100kgs Accessories		1	C53-010 (Pair)
SHOCK ABSORBER  Type 'G' 'H' 'J'				
	Heavy Duty Gas	H	2	GS53-202

REAR		TYPE	QTY	PART NUMBER
COIL SPRING Type 'C' 				
SUITS: Rigid Axle Models				
	Linear Rate Standard Height		1	C53-009 (Pair)
	Linear Rate Raised Height (35mm Lift)		1	C53-011 (Pair)
SUITS: Independent Suspension				
	Linear Rate Raised Height (40mm Lift)		1	C53-013 (Pair)
SHOCK ABSORBER  Type 'A' 'B' 'C'				
SUITS: Rigid Axle Models				
	Heavy Duty Gas	B	2	GS57-621
SUITS: Independent Suspension				
	Heavy Duty Gas	B	2	GS57-639S