



**MAKE:** MITSUBISHI      **TYPE:** Challenger (Australia)

**MODEL:**                      **YEAR:** 2008 on

**DETAIL:** Montero Sport (South America)  
Pajero Sport (Thailand, USA)

MITS-61

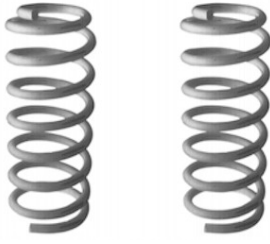

FRONT		TYPE	QTY	PART NUMBER
<b>COIL SPRING</b> Type 'C' 				
	Linear Rate Standard Height		1	<b>C43-186</b> (Pair)
	Linear Rate Raised Height (15mm Lift) Softer Option		1	<b>C43-192</b> (Pair)
	Linear Rate Raised Height (40mm Lift)		1	<b>C43-188</b> (Pair)
<b>SHOCK ABSORBER</b>  Type 'G' 'H' 'K'				
	Heavy Duty Gas	K	2	<b>GS43-800</b>

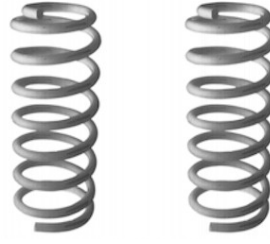
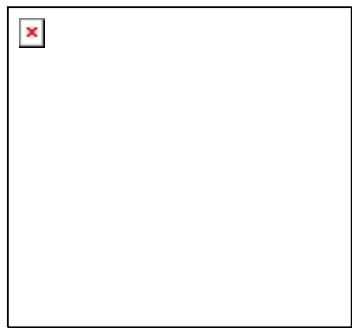
REAR		TYPE	QTY	PART NUMBER
<b>COIL SPRING</b> Type 'C' 				
	Linear Rate Standard Height		1	<b>C43-099</b> (Pair)
	Linear Rate Raised Height (20mm Lift)		1	<b>C43-097</b> (Pair)
	Variable Rate Raised Height (35mm Lift)		1	<b>C43-043V</b> (Pair)
	Linear Rate Raised Height (40mm Lift)		1	<b>C43-203</b> (Pair)
	Linear Rate Raised Height (40mm Lift) 250Kg to GVM		1	<b>C43-101</b> (Pair)
				
	Heavy Duty Gas	A	2	<b>GS43-785</b>